

- Single mechanical seal
- Balanced
- Outside mounted
- Independent of the direction of shaft rotation
- Multi-spring
- PTFE bellows

Operating limits*		
Pressure	p_{max}	1.2 MPa
Temperature	t_{max}	80 °C
Speed	v_{max}	8 m/s (2500 rpm)

* - see note on page 3.

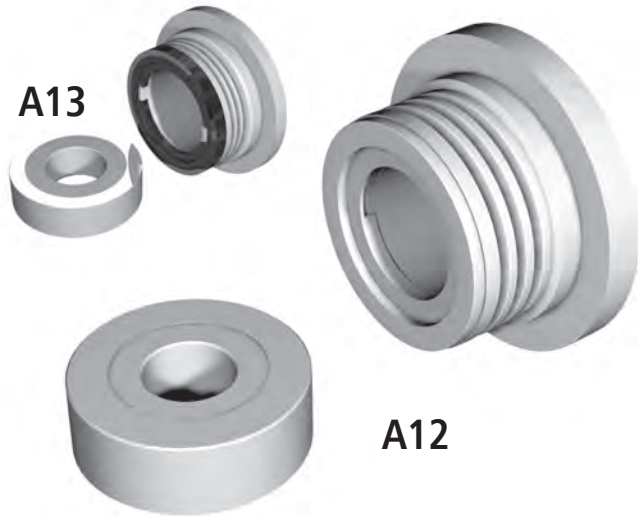
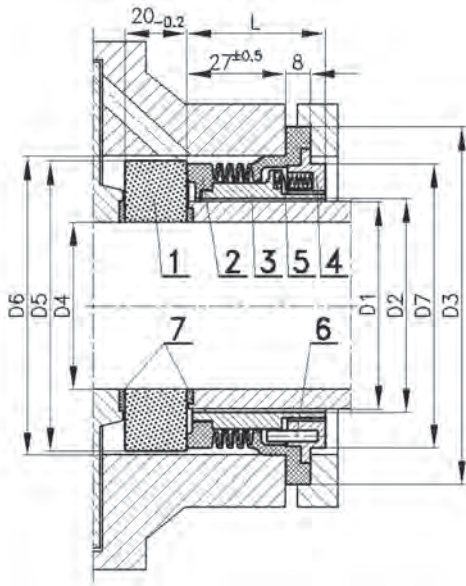

Legend A12, A13

1. Rotating ring
2. A12/A13 bellows*
3. Sleeve
4. Cage
5. Springs
6. Driver
7. Flat gaskets

Legend B12

1. Rotating ring
2. Stationary ring
3. O-ring
4. Seal housing
5. Driver
6. Spring
7. Flat gaskets
8. Flat gasket

* - The A13 version with carbon insert is available. It is recommended for abrasive media.

Dimensions (mm)

D1	D2	D3	D4	D5	D6	D7	L
30	32	78	22	56	60,1	54	38
35	37	83	22	56	65,1	60	38
40	42	88	32	66	70,1	65	41
45	47	94	32	70	75,1	70	41
50	52	100	40	76	80,1	75	41
60	62	110	37	86	90,1	85	41
70	72	120	60	97	100,1	95	41
80	82	130	70	107	110,1	105	41

Other dimensions are available as an option. Please contact ANGA.

The B12 version is intended for operating with aggressive chemical media of temperature above 80°C.

Application

The A12, A13 and B12 mechanical seals are intended for operating with extremely aggressive chemical compounds (for the A13 and B12 seals, presence of small abrasive particles is permitted). Mechanical seals are intended for centrifugal pumps and other equipments with rotating shafts.

Materials

Part	Code A12	Code A13	Code B12
Rotating ring	V, Q		
Stationary ring	Y	B	B, Q
Secondary, flexible seals	T1		T1, V, K, E
Spring	M		
Other metal parts	-		G, T2

